

# Vertical Wear Shrouds for Excavators, Loaders, and Front Shovels

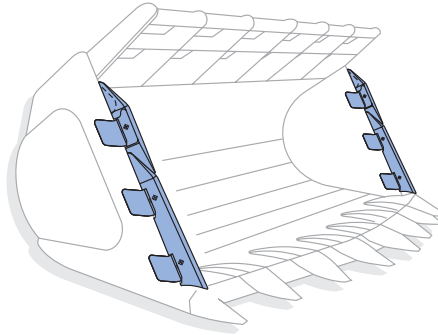

Vertical Shroud	Machine		Lower Weldment	Lower Fastener (Rubber Plug & Pin)	Upper Weldment	Upper Fastener (Rubber Plug & Pin)
	Exc./F. Shovel Wt. (Lbs.)	Loader Cu. Yards				
<b>VS385</b>	up to 60,000	up to 6	*VSM100WN	EMI-004 EMP-003	*VSM100WN	EMI-004 EMP-003
<b>VS410</b>	up to 60,000	up to 6	VS410WNA	N/A	VS410WNB	EMI-004 EMP-003
<b>VS450</b>	70,000 - 150,000	6 - 8	*VSM100WN	EMI-004 EMP-003	*VSM100WN	EMI-004 EMP-003
<b>VS500</b>	175,000 - 350,000	9 - 15	*VSM150WN	EMI-004 VS272P	*VSM150WN	VSR3 VSP3
<b>VS181</b>	200,000 - 400,000	9 - 22	VS181-W1	N/A	VS181-W2	EMI-004 EMP-003
<b>VS550</b>	250,000 - 400,000	15 - 25	*VSM200WN	EMI-004 VS272P	*VSM200WN	VSR3 VSP3

\* Optional Weldments include: VSM100WN (1.0"), VSM150WN (1.5"), VSM175WN (1.75"), VSM200WN (2.0"), VSM250WN (2.5").

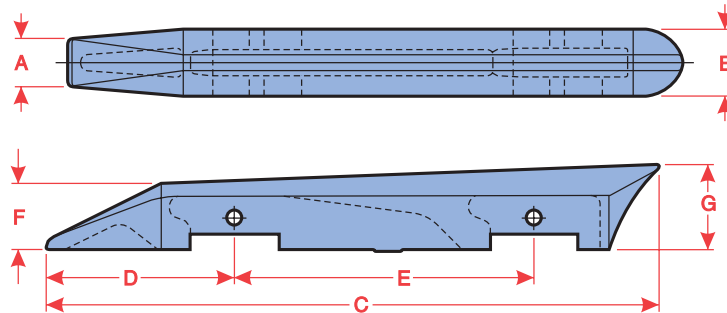
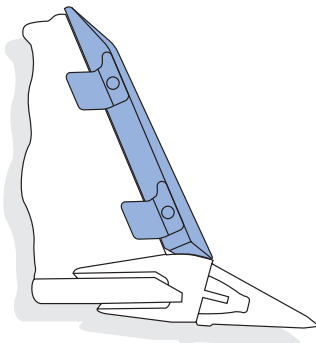

Part Number	Wt. (Lbs./Kg.)	A	B	C	D	E	F	G
<b>VS385</b>	32.8/14.9	1-5/8 (41)	2-3/8 (73)	27-1/8 (689)	10-1/8 (257)	10-11/16 (271)	3-3/4 (95)	4-7/32 (107)
<b>VS410</b>	29.0/13.2	1-5/8 (41)	2-7/8 (73)	27-1/4 (692)	9 (229)	N/A	2-1/2 (64)	4-1/4 (108)
<b>VS450</b>	42.5/19.3	1-11/16 (43)	2-5/8 (67)	30-11/32 (771)	10-1/8 (257)	13-1/2 (343)	3-3/4 (95)	4-5/8 (117)
<b>VS500</b>	66.0/30.0	2-1/2 (64)	3-7/16 (87)	32-7/8 (835)	10-1/8 (257)	16 (406)	3-21/32 (93)	4-5/8 (117)
<b>VS181</b>	62.0/28.1	2-3/8 (60)	3-13/16 (97)	35 (889)	10-1/8 (257)	N/A	3 (76)	6 (152)
<b>VS550</b>	86.0/39.0	2-1/2 (64)	4 (102)	35-3/4 (908)	10-3/4 (273)	17-1/8 (435)	4 (102)	5 (127)



# Installation Instructions for VS385, VS450, VS500, and VS550



## Step 1

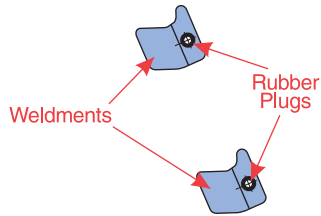

Install rubber plugs into both upper and lower weldments.

## Step 2

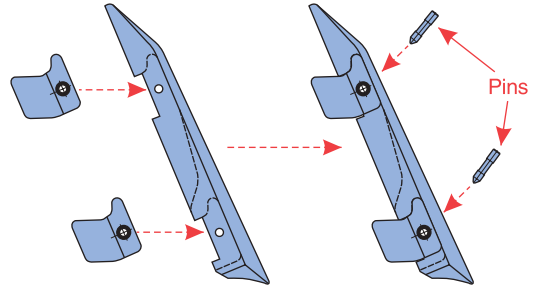

Position both weldments into vertical shrouds and install pins.

## Step 3

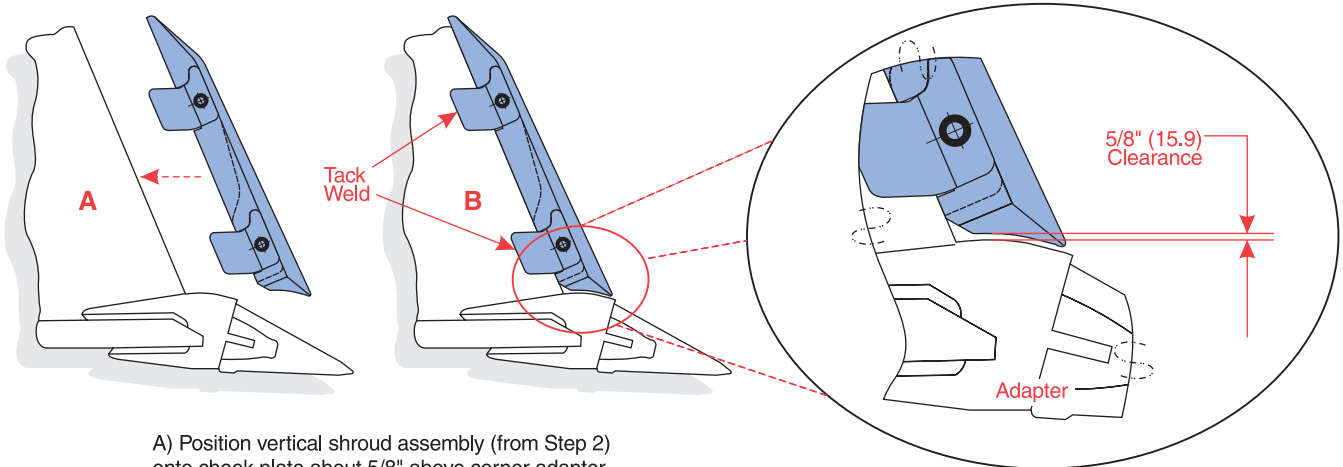

A) Position vertical shroud assembly (from Step 2) onto cheek plate about 5/8" above corner adapter.  
B) Tack weld both weldments onto cheek plate.

## Step 4

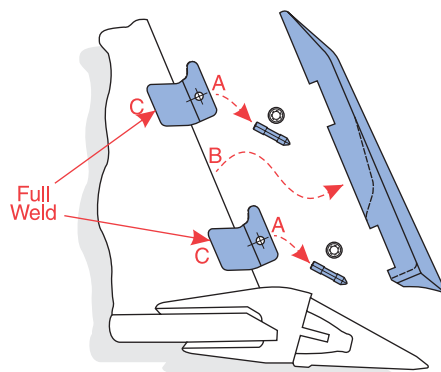

A) Remove pins and plugs from weldments.  
B) Remove vertical shroud.  
C) Secure both weldments with a full weld.

## Step 5

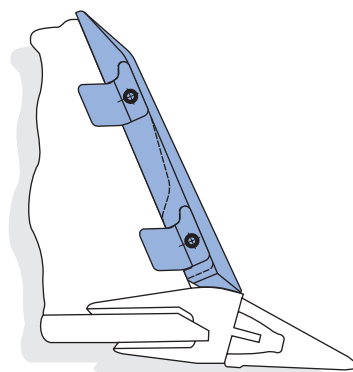

Reposition vertical shroud and reinstall pins and plugs.

# Installation Instructions for VS410 and VS181

## Step 1

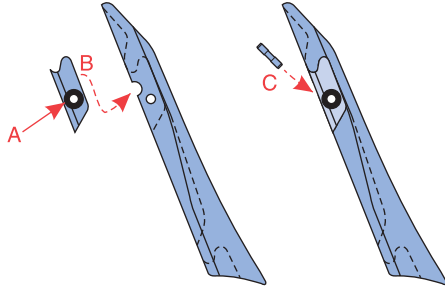

- A) Install rubber plug into upper weldment.
- B) Position inside vertical shroud.
- C) Assemble with pin.

Note: VS410 upper weldment - VS410WNB  
VS181 upper weldment - VS181-W2

## Step 2

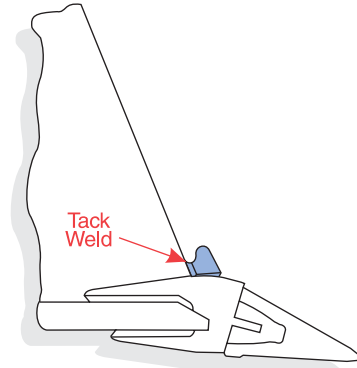

Tack weld lower weldment directly on top of corner adapter.  
Note: lower weldments (VS410WNA & VS181-W1) have no pins or plugs.

## Step 3

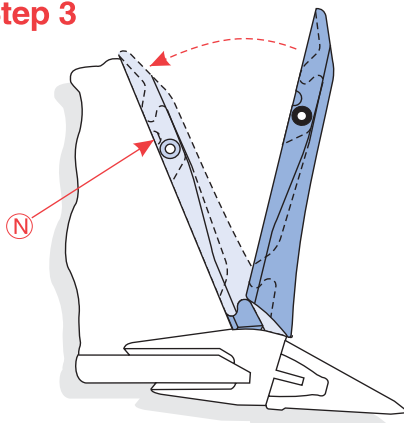

- A) Position vertical shroud on lower weldment. Rotate until it comes into contact with cheek plate.
- B) Tack weld upper weldment through port (N) to cheek plate.

## Step 4

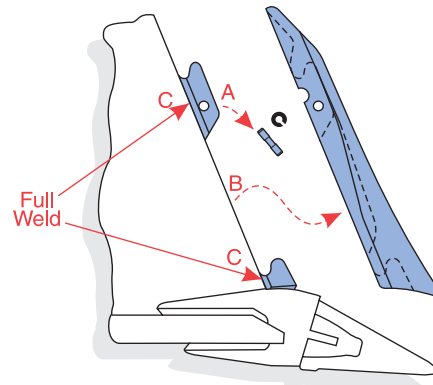

- A) Remove pin and plug from from upper weldment.
- B) Remove vertical shroud.
- C) Secure both weldments with a full weld.

## Step 5

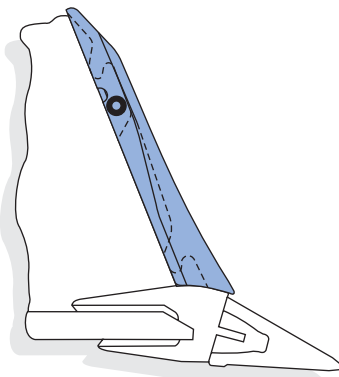

Reposition vertical shroud and reinstall pin and plug.

# Vertical Shroud Extension

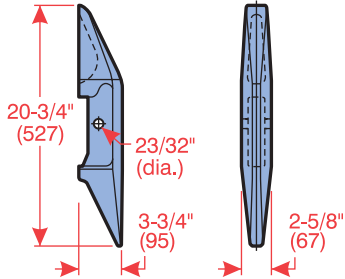

**VS450EXT** (24.3 Lbs./11 Kgs.)

The VS450EXT can be used to extend the VS385, VS450 and VS500 shrouds. Multiple extensions can be "stacked" in order to offer additional protection.

## Fasteners

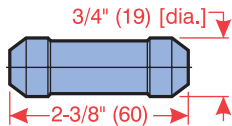

**Pin (EMP-003)**

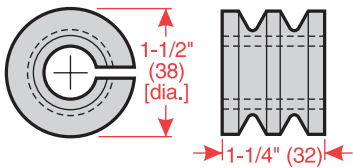

**Rubber Plug (EMI-004)**

Used with: VS410, VS181 upper  
VS385 upper, lower  
VS450 upper, lower

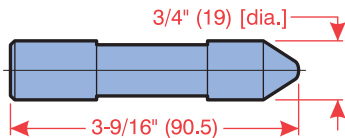

**Pin (VSP3)**

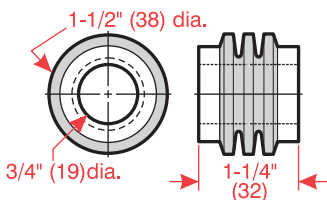

**Rubber Bushing (VSR3)**

Used with: VS500 upper, lower  
VS550 upper, lower

**Safety First:** Hensley recommends that you use a soft-faced hammer and ANSI-approved (Z87.1) eye protection while using our products.

# Weldments

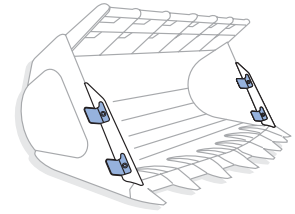

## Upper & Lower Weldments for VS385, VS450, VS500, and VS550

Part Number	Inches (mm)				Wt. (Lbs./Kgs.)
	A	B	C	D	
VSM100WN	5-3/4 (146)	6 (152)	2-3/4 (70)	1-1/16 (27)	10.9/4.9
VSM150WN	5-3/4 (146)	6 (152)	3-7/16 (87)	1-9/16 (40)	12.3/5.6
VSM175WN	5-3/4 (146)	6 (152)	3-7/16 (87)	1-27/32 (47)	12.5/5.7
VSM200WN	5-3/4 (146)	6 (152)	3-7/16 (87)	2-1/16 (52)	11.9/5.4
VSM250WN	5-3/4 (146)	6-1/4 (159)	3-15/16 (100)	2-9/16 (65)	11.6/5.3

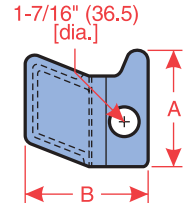
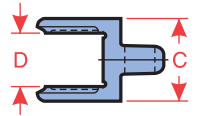

## Upper Weldments for VS410 and VS181

Part Number	Inches (mm)		Wt. (Lbs./Kgs.)
	A	B	
VS410WNB	5-5/16 (135)	2-1/8 (54)	2.9/1.3
VS181-W2	5-5/16 (135)	2-1/8 (54)	2.9/1.3

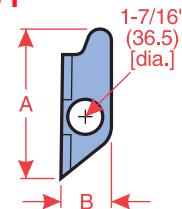

## Lower Weldments for VS410 and VS181

Part Number	Inches (mm)			Wt. (Lbs./Kgs.)
	A	B	C	
VS410WNA	3 (76)	2-13/32 (61)	2 (51)	3.0/1.4
VS181-W1	4-1/2 (114)	3-3/16 (81)	3-3/4 (95)	3.4/1.5

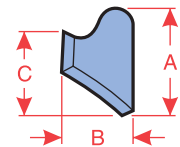

## Your Authorized Hensley Dealer:

PWHC Docs\VERTICAL WEAR SHROUDS 0203



Hensley Industries, Inc.  
2108 Joe Field Road, Dallas, Texas 75229, U.S.A.

Customer Service:

U.S. & Can.-Tel. (888) 406-6262, Fax (888) 241-3274  
All Other Locations-Tel. (972) 406-6262, Fax (972) 241-3274  
www.hensleyind.com

COPYRIGHT © 2004 HENSLEY INDUSTRIES, INC.

THIS PUBLICATION PROTECTED BY THE COPYRIGHT LAWS OF THE UNITED STATES. UNAUTHORIZED DUPLICATION OR DISTRIBUTION IS PROHIBITED.